



DC Power Supply

GP-1305/GP-1503

GP-1505/GP-1310

Operation Manual

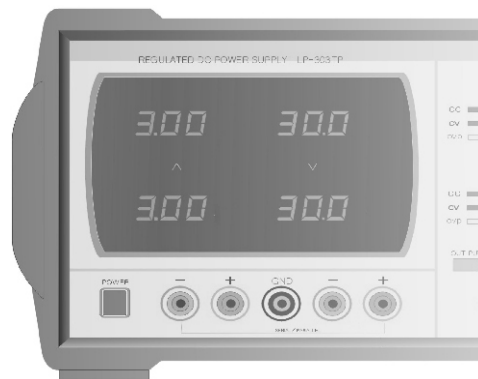

 **EZ Digital Co.,Ltd.**

SAFETY SUMMARY

SAFETY PRECAUTIONS

Please take a moment to review these safety precautions.
They are provided for your protection and to prevent damage to the power supply.
This safety information applies to all operator and service personnel.

NOTE : If the equipment is used in a manner not specified by the manufacturer, the protection provided by the equipment may be impaired.

CAUTION AND WARNING STATEMENTS.

CAUTION : Is used to indicate correct operation or maintenance procedures in order to prevent damage to or destruction of the equipment or other property.

WARNING : Calls attention to a potential danger that requires correct procedures of practices in order to prevent personal injury.

SYMBOLS



Caution(Refer to accompanying documents)



PROTECTIVE CONDUCTOR TERMINAL

INTRODUCTION

Thank you for purchasing an EZ DIGITAL product.

The instruments produced by EZ DIGITAL company are high technology products made under strict quality control.

We guarantee exceptional precision and utmost reliability.

For proper use of this product, please read this manual carefully.

1. To maintain the precision and the reliability of the product, use it in the standard settings.

Operating temperature : 5°C ~ +40°C

Operating humidity : 50% ~ 80%

Storage temperature : 0°C ~ +70°C

Storage humidity : less than 85%

2. For quality improvement, the exterior and specifications of the product can be changed without notice.

3. Should any further information be required, please contact our company's service center or sales outlet.



4. To carry the equipment, you should be used the both of handle.
Don't carry to take the upper side of the vessel.

WARRANTY

Warranty service covers one year from the date of original purchase.

In case of technical failure within a year, repair service will be provided by our service center or sales outlet free of charge.

We charge for repairs after the one-year warranty period expires.

When the failure is the result of user's neglect, natural disaster or accident, we charge for repairs regardless of the warranty period.

For more information on repair service, be sure to contact our service center or sales outlet.

CONTENTS

1. INTRODUCTION	1
2. PRECAUTIONS	3
2-1. Exchanging Method of Fuse	3
2-2. Installaion and Handling Precautions	5
2-3. Cleaning	6
3. SPECIFICATION	7
4. DESCRIPTION OF PANEL FUNCTIONS	9
4-1. Front Panel	9
4-2. Rear Panel	10
4-3. Front,Rear Panel's Functions	11

5. OPERATIONS	13
5-1. Pre-Operational Checking	13
5-2. Operational Procedure	13
6. SURROUNDING ENVIRONMENT OF USE	13

1. INSTRUCTIONS

GP-Single Series are one channel Regulated DC Power Supply.
They have low ripple ,high stability and excellent electric features.

Constant Voltage,Constant Current function can provide stable voltage and current.
So they have Voltage and Current Funtion to adjust Output Value easily.

For protection ,Current limit and Over Voltage Protection functions are added.
So,it can protect the load and equipment

When O.V.P happens , the LED Lamp (Yellow) is displayed.
So they can minimize the damage of equipment and the load.

1

The unit is equipped with DC output on/off function.

So without turning off the power you can control the output to minimize the damage of equipment and the load.

Without output of current and voltage,you can control temporary value what you want.

To understand the statements of DC Power Supply , it has digital Voltage Meter and Ampere Meter,Constant Current LED (C.C) and Constant Voltage LED (C.V)
Over Voltage Protection (O.V.P) LED , DC Output ON/OFF functions.

So you can see the ststements of operation easily.

The selector switch of input power is used either for AC 115V or 230V.
If you change the selector switch , refer to page 4.

2

2. PRECAUTIONS

2-1. To Replace the Fuse

Pull out F1 below with screw driver and get rid of F1, take out spare Fuse in the holder
Put it in the position of F1.

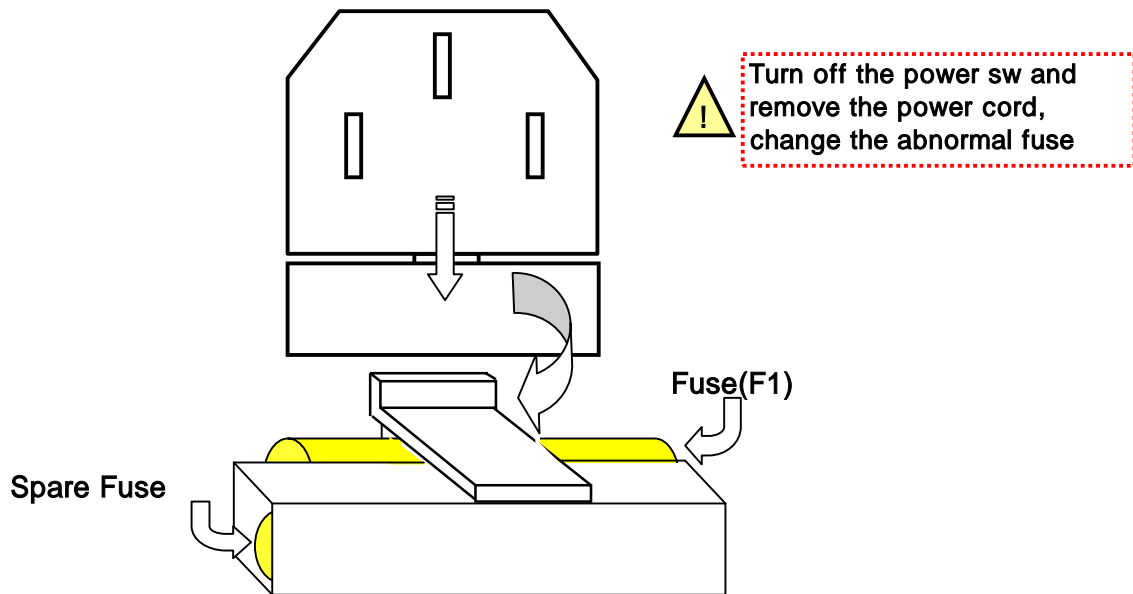

3

Input Voltage Selection and Fuse Rating

Input Voltage	Select Switch	Fuse No.	Fuse Rate(250V)			
			1305	1310	1503	1505
AC 90~110	115	F1	T2.5L	T7.0L	T2.5L	T5.0L
AC108~132						
AC198~242	230	F1	T1.6L	T4.0L	T1.6L	T2.0L
AC207~250						

 For continued protection against fire, replace the line fuse only with a fuse of the specified type and rating.

4

2-2. INSTALLATION AND HANDLING PRECAUTIONS



When placing the Power Supply to use at your workplace, observe the following precautions for best instrument performance and the longest using life.

1. Avoid placing this instrument in an extremely hot or cold place. Specifically, don't leave this instrument in a close car, expose to sunlight in midsummer, or to hot heater.
2. Don't use this instrument immediately after bringing it in from the cold. Allow time for it to warm to room temperature. Similarly don't move it from a warm place to a very cold place, as condensation might impair its operation.
3. Do not expose the instrument to wet or dusty environments.
4. Do not place liquid-filled containers (such as coffee cups) on top of this instrument. A spill could seriously damage the instrument.
5. Do not place this instrument where it is subject to severe vibration, or strong blows.
6. Do not place heavy objects on the case, or otherwise block the ventilation holes.

5

-
-
7. Do not use this Power Supply in strong magnetic fields, such as near motors.
 8. Don't insert wires, tools, etc. through the ventilation holes.
 9. Do not leave a hot soldering iron near the instrument.
 10. Do not place this instrument face down on the ground, or damage to the knobs may result.
 11. Do not connect other power source to the output terminal.
 12. Before the power switch on, you should set the voltage & current volume to the min.(CCW)
 13. Before the power switch on, don't connect the load to output terminal.(Refer to p13)

2-3. CLEANING

1. To clean stained case, lightly rub the stained area with a soft cloth dipped in a neutral detergent.
2. If the surface of the panel is dirty, use the same method to clean. If the panel is heavily stained, rub the affected area lightly with a soft cloth soaked in light neutral detergent or alcohol.
3. Never use highly volatile material such as benzene or paint thinner.

6

3. SPECIFICATIONS

ITEMS		MODEL	GP - 1305	GP - 1305	GP - 1503
Output Voltage & Current			0~30V/0~5A	0~30V/0~5A	0~50V/0~3A
C.V	Line Regulation		0.01% + 2mV		
	Load Regulation		0.01% + 3mV		
	Ripple & Noise		1mVrms		
C.C	Line Regulation		0.1% + 3mA		
	Load Regulation		0.2% + 3mA		
	Ripple & Noise		5mArms		
Meter accuracy	DC output s/w on		±(1% of rdg + 1dgt)		
	DC output s/w off		±(3dgt of rdg)		
Over voltage protection			When the output voltage is exceed by approx 110% of the maximum voltage,it will be operated.		
Output on/off control			Output is produced only when power s/w and outoput s/w is on.		
No load current limit function			Built - in		
Insulation	Chassis ~ Terminal		20M or above(DC500V)		
	Chassis ~ AC Code		50M or above(DC500V)		
Ambient Temperature			0 ~ 40		
Input power source			AC100V/110V/220V/230V , 50/60Hz		
Dimension(W x H x D)			235mm x 136mm x 370mm		
Weight(Approx)			7.8Kg	12.5Kg	7.8Kg
Accessories			Manual , AC Power cord , Test leads(2ea), Short Bar		

7

ITEMS		MODEL	GP - 1310
Output Voltage and Current			0~30V/0~10A
C.V	Line Regulation		0.01% + 2mV
	Load Regulation		0.01% + 3mV
	Ripple & Noise		1mVrms
C.C	Line Regulation		0.1% + 5mA
	Load Regulation		0.2% + 5mA
	Ripple & Noise		8mArms
Meter Accuracy	DC output s/w on		±(1% of rdg + 1dgt)
	DC output s/w off		±(3dgt of rdg)
Over Voltage protection			When the output voltage is exceed by approx 110% of the maximum voltage,it will be operated.
Output on/off control			Output is produced only when power s/w and outoput s/w are on(to prevent unexpected output)
No Load current limit control function			Built- in
Insulation	Chassis ~ Terminal		20M or above(DC500V)
	Chassis ~ AC code		50M or above(DC500V)
Ambient temperature			0°C ~ 40°C
Power source			AC100V/110V/220V/230V, 50/60Hz
Dimension(W x H x D)			235mm x 136mm x 370mm
Weight(approx)			10.5Kg
Accessories			Manual, AC Power cord, Test leads(2ea), Short Bar

8

4. The Description of Panel

4-1. Front panel

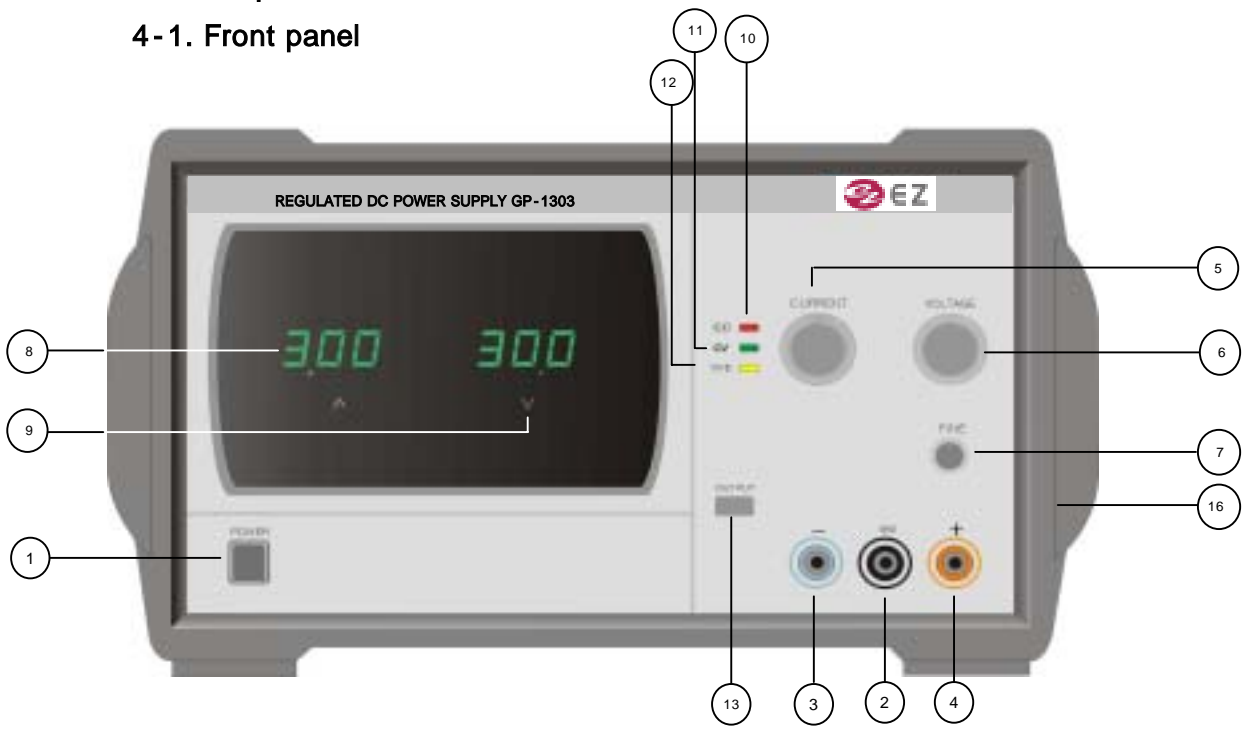

9

4-2. Rear Panel

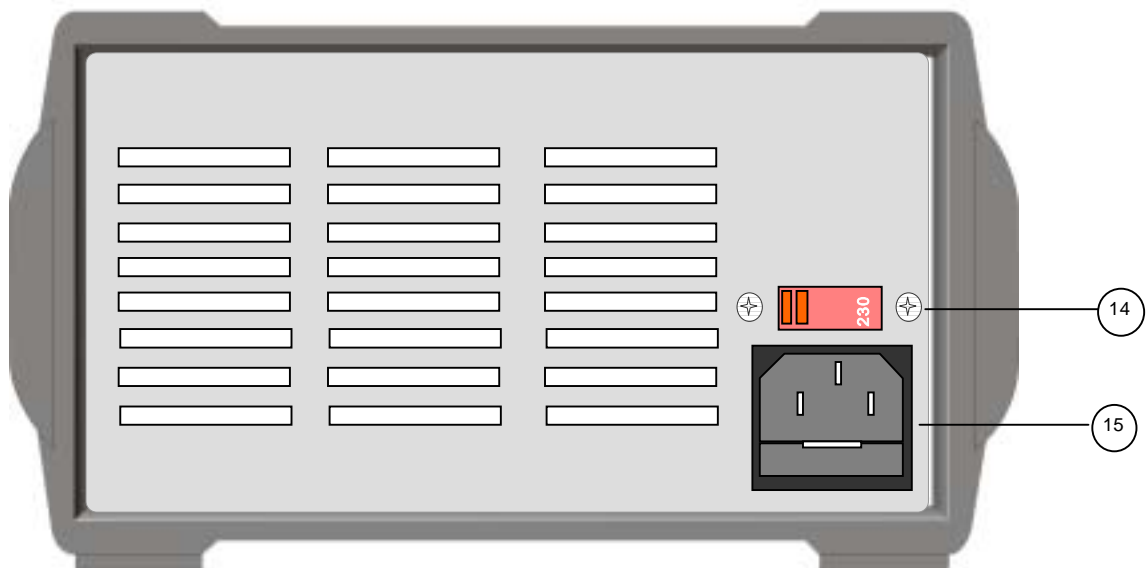



Before the connection of AC power, you must be check selector switch and line voltage.

4-3. Description of Panel's Function

1. Power Switch : This switch turns on and off the power
2. GND terminal () : chassis GROUND terminal.
3. (-) Output : (-) Output terminal.
4. (+) Output : (+) Output terminal.
5. Current Knob : Current limit Volume.
6. Voltage Knob(Coarse) : Voltage main control Volume.
7. Voltage Knob(Fine) : Voltage Fine Control Volume.
8. Current Meter : Current Display Meter.(3-Digit)
9. Voltage Meter : Voltage Display Meter.(3-Digit)
10. C.C LED (Red) : Display LED for Constant Current operating.

11

-
11. C.V LED (Green) : Display LED for Constant Voltage operating.
 12. O.V.P Display (Yellow) : Display LED that means Voltage is flowing over 110% of max. o voltage. (output Voltage cut off at the same time.)
 13. DC Output On/Off Switch : It can control Output without turning off Power Switch.
ON() : Output as set value.
OFF() : Output is cut off.
 14. Voltage Select Switch : For selecting the input voltage 115 or 230V.
(Reference page 4)
 15. AC Power Inlet : Power input Socket & Fuse is set inside (Spare Fuse included)
 16. Vessel holder : Holder for moving instrument easily.

12

5. Operation

5-1 Checking before Operation

You should check for damage to equipment appearance(output terminal,Current and Voltage Meter,Switch,Volume and so on),check AC Power Select Switch.
If there are no problems , Connect AC Power.

5-2 Operational Procedure

- 1) You should set DC Output S/W OFF.
- 2) Connect the load into Terminal.
- 3) Turn on Power Switch.
- 4) Change Voltage ,Current Knob seeing Voltage,Current Meter.
- 5) When you turn the DC OUTPUT S/W ON , the selected current and voltage are output
(Even though the load changes, Current won't flow over current limit value)
- 6) When Current goes over the set value, CC Lamp is turned on into Constant Current.

13

(Voltage and Current Display)

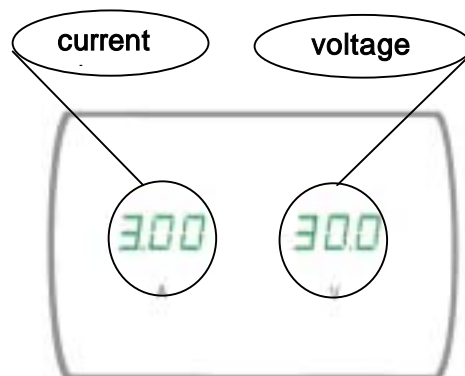

(DC Output S/W OFF)

Setting value of Current ,Voltage
when you use Voltage in 30V
when you use Current in 3A



(DC Output S/W ON)

True Output value
30.0V
3.00A

14

6. NOTES ON ENVIRONMENTAL CONDITION

6-1. Avoid using the unit in such a place where the ambient temperature exceeds 40°C or under the direct sun . Limit the maximum output current when the unit is used in such a place where ventilation is interrupted or radiation exists from other equipments.

6-2. Use the instrument within 10% tolerance of the specified voltage from the power source.

6-3. Environmental conditions

- 1) Indoor use
- 2) Altitude : up to 2,000m
- 3) Relative humidity : 50% ~ 80%
- 4) Installation : Category(Overvoltage category)
- 5) Pollution : Degree2

